

(1) EXTERIOR SECTION PARTS LIST

<u>Mark No.</u>	<u>Description</u>	<u>Part No.</u>	<u>Mark No.</u>	<u>Description</u>	<u>Part No.</u>
	1 MAIN Assy	DWX3019	21	Bottom Packing	DEC3186
	2 SRV Assy	DWX3020	22	Front Plate	DNH2869
	3 JACB Assy	DWX3023	23	Shield Case	DNH2872
	4 ACIN Assy	See Contrast table (2)	24	Main PCB Stay	DNH2874
	5 USBA Assy	DWX3044	25	Heatsink	DNH2885
⚠	6 POWER SUPPLY Assy	DWR1463	26	Bottom Plate	See Contrast table (2)
	7 USB Cable	DDA1040	27	USB Holder	DNK5423
	8 40P FFC	DDD1500	28	Damper	CNV6011
	9 Connector Assy 6P	DKP3831	29	Earth Spring	DBH1398
	10 Connector Assy 12P	DKP3838	30	Float Spring (G5)	DBH1494
	11 Connector Assy 13P	DKP3849	31	Mecha Plate	DNH2642
NSP	12 Earth Lead Unit	DE007VF0	NSP 32	CCC S & E Label	See Contrast table (2)
	13 Power Knob	DAC2484	33	Cord Clamper (Steel)	RNH-184
	14 Lock Plate	DNH2905	34	•••••	
⚠	15 Chassis	See Contrast table (2)	35	•••••	
	16 USB Cover	DNK4999	36	DM Screw (FTC)	DBA1260
	17 Earth Plate	DBK1224	37	Screw	BBZ30P060FTB
	18 USB Earth Plate	DBK1351	38	Screw	BBZ30P060FTC
NSP	19 Silicon Rubber D5 L	DEB1456	39	Screw	BPZ30P080FNI
	20 Cushion	DEC3177	40	Screw	BPZ30P200FTB
			41	Screw	BPZ30P080FTB
			42	Screw	BSZ30P060FTC

(2) CONTRAST TABLE

CDJ-900/CUXJ, SYXJ8, FLXJ, KXJ5 and AXJ5 are constructed the same except for the following:

Mark	No.	Symbol and Description	CDJ-900 /CUXJ	CDJ-900 /SYXJ8	CDJ-900 /FLXJ	CDJ-900 /KXJ5	CDJ-900 /AXJ5
⚠	4	ACIN Assy	DWR1461	DWR1462	DWR1462	DWR1462	DWR1462
	15	Chassis	DNK5358	DNK5352	DNK5359	DNK5362	DNK5360
	26	Bottom Plate	DNH2895	DNH2871	DNH2896	DNH2899	DNH2897
NSP	32	CCC S & E Label	Not used	Not used	Not used	Not used	DRW2310

9.3 CONTROL PANEL SECTION

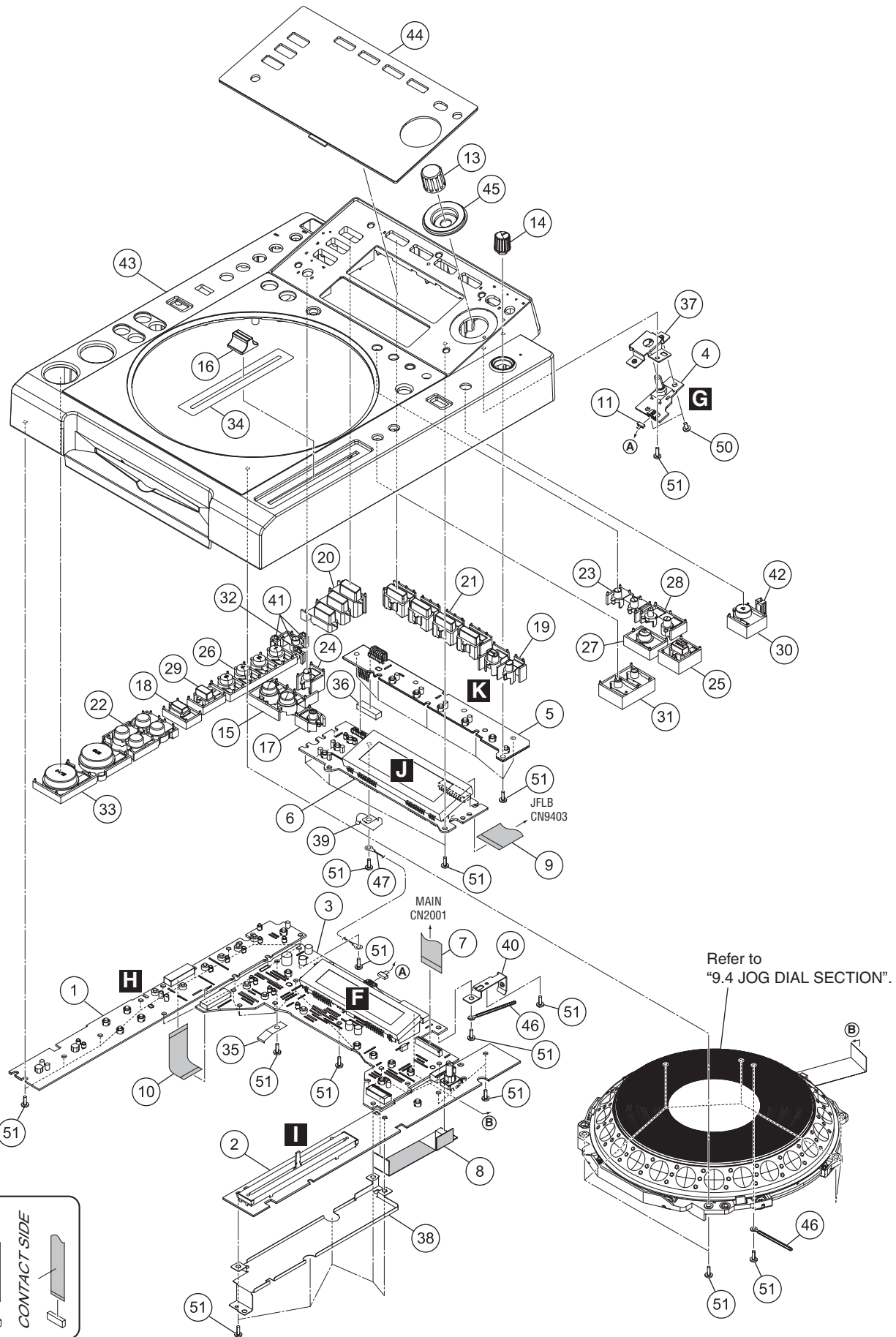

CONTROL PANEL SECTION PARTS LIST

<u>Mark No.</u>	<u>Description</u>	<u>Part No.</u>	<u>Mark No.</u>	<u>Description</u>	<u>Part No.</u>
1	KSWB Assy	DWS1416	46	Cord Clamper (Steel)	RNH-184
2	SLDB Assy	DWS1417	47	Earth Lead Unit	DDF1032
3	DFLB Assy	DWX3021	48	•••••	
4	ENCB Assy	DWX3022	49	•••••	
5	MSWB Assy	DWS1415	50	Screw	BBZ30P060FTC
6	BFLB Assy	DWX3025	51	Screw	BPZ30P080FNI
7	26P FFC	DDD1445			
8	13P FFC	DDD1449			
9	22P FFC	DDD1489			
10	20P FFC	DDD1501			
11	Connector Assy	PF04PP-Q17			
12	•••••				
13	Rotary Knob C	DAA1194			
14	Dial Knob	DAA1246			
15	Loop Knob	DAC2066			
16	Slide Knob	DAC2067			
17	Re-loop Knob	DAC2291			
18	Reverse Knob	DAC2364			
19	Menu Button	DAC2490			
20	Media Select Button	DAC2491			
21	Mode Select Button	DAC2492			
22	Set Button (SEARCH)	DAC2495			
23	Set Button (CALL)	DAC2497			
24	Time Button	DAC2498			
25	Vinyl Knob	DAC2542			
26	Auto Beat Roop Knob	DAC2543			
27	Quick Return Knob	DAC2544			
28	DEL MEMO Knob	DAC2545			
29	Beat Select Button	DAC2546			
30	Eject Button	DAC2548			
31	Tempo Button	DAC2549			
32	USB Stop Button	DAC2550			
33	Play Knob	DAC2596			
34	Slide Sheet 1C	DAH2404			
35	Earth Plate	DBK1224			
36	FFC Guard	DEC2586			
37	Encoder Stay	DNF1840			
38	Earth Plate	DNH2875			
39	Earth Plate S	DNH2906			
40	Earth Plate L	DNH2907			
41	USB Lens	DNK5353			
42	EUP Lens	DNK5408			
43	Control Panel	DNK5440			
44	Display Panel	DNK5442			
45	Encoder Ring	DNK5489			



9.4 JOG DIAL SECTION

1

2

3

4

A

B

C

D

E

F

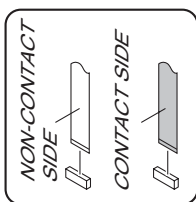
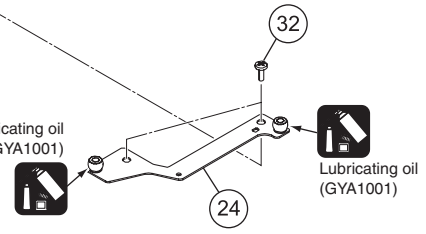
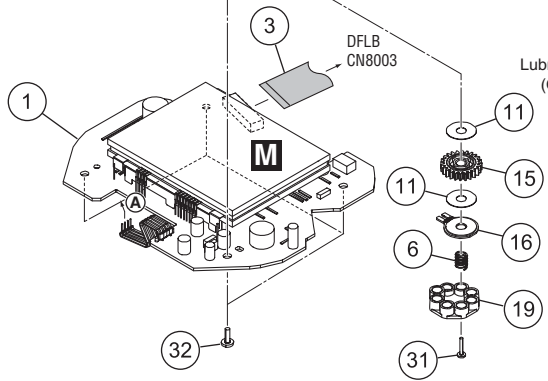
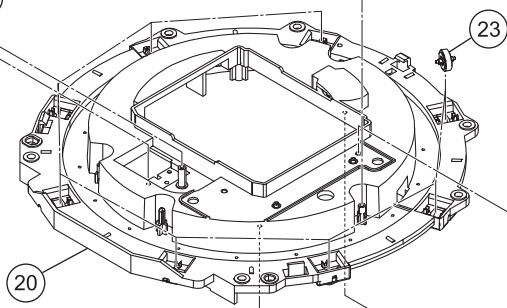
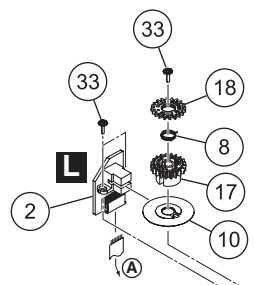
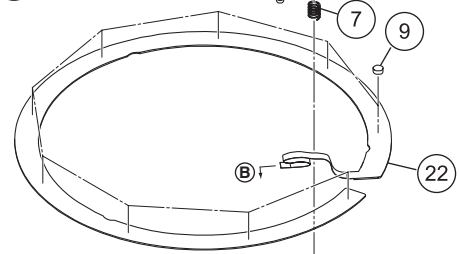
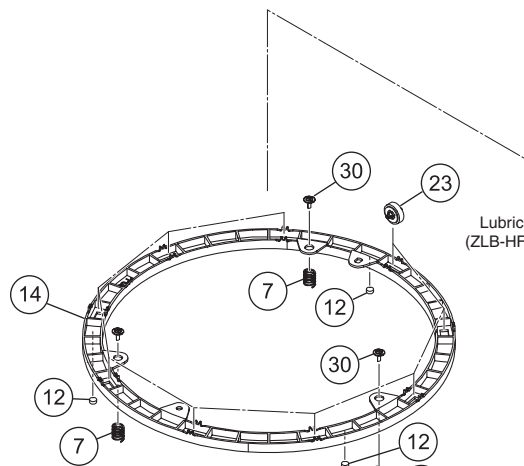
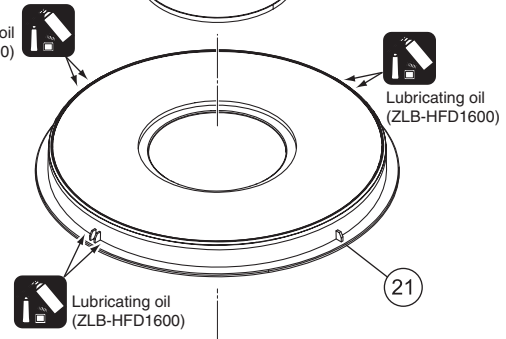
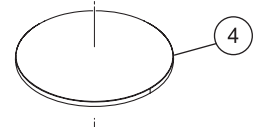
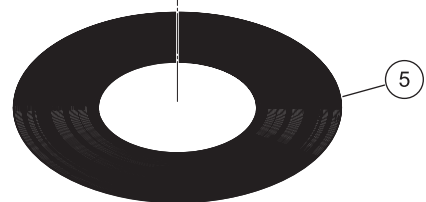
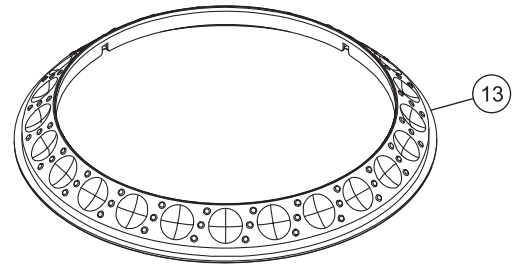

1

2

3

4

JOG DIAL SECTION PARTS LIST

<u>Mark No.</u>	<u>Description</u>	<u>Part No.</u>	
1	JFLB Assy	DWX3024	
2	JOGB Assy	DWX3026	A
3	19P FFC	DDD1490	
4	JOG Panel	DAH2609	
5	JOG Plate M	DAH2690	
6	Load Spring	DBH1680	
7	SW spring	DBH1681	
8	Encoder Spring	DBH1710	
9	SW Cushion HH48/2	DEC2538	
10	Encoder Plate	DEC2889	
11	Washer	DEC3137	B
12	Ring Cushion L24/2.0	DEC2958	
13	JOG B	DNK4068	
14	SW Ring	DNK5233	
15	Load Gear	DNK5236	
16	Smoother	DNK5237	
17	Gear A	DNK5241	
18	Gear B	DNK5242	
19	Adjust Plate	DNK5300	
20	JOG Holder M	DNK5356	C
21	JOG Dial A	DNK5357	
22	Sheet SW	DSX1078	
23	Roller A Assy	DXB2010	
24	JOG Stay Assy	DXB2015	
25	•••••		
26	•••••		
27	•••••		
28	•••••		
29	•••••		
30	Screw (FE)	DBA1265	D
31	Screw	BPZ20P100FTC	
32	Screw	BPZ30P080FNI	
33	Screw	IPZ20P060FTC	

9.5 SLOTIN MECHA SECTION

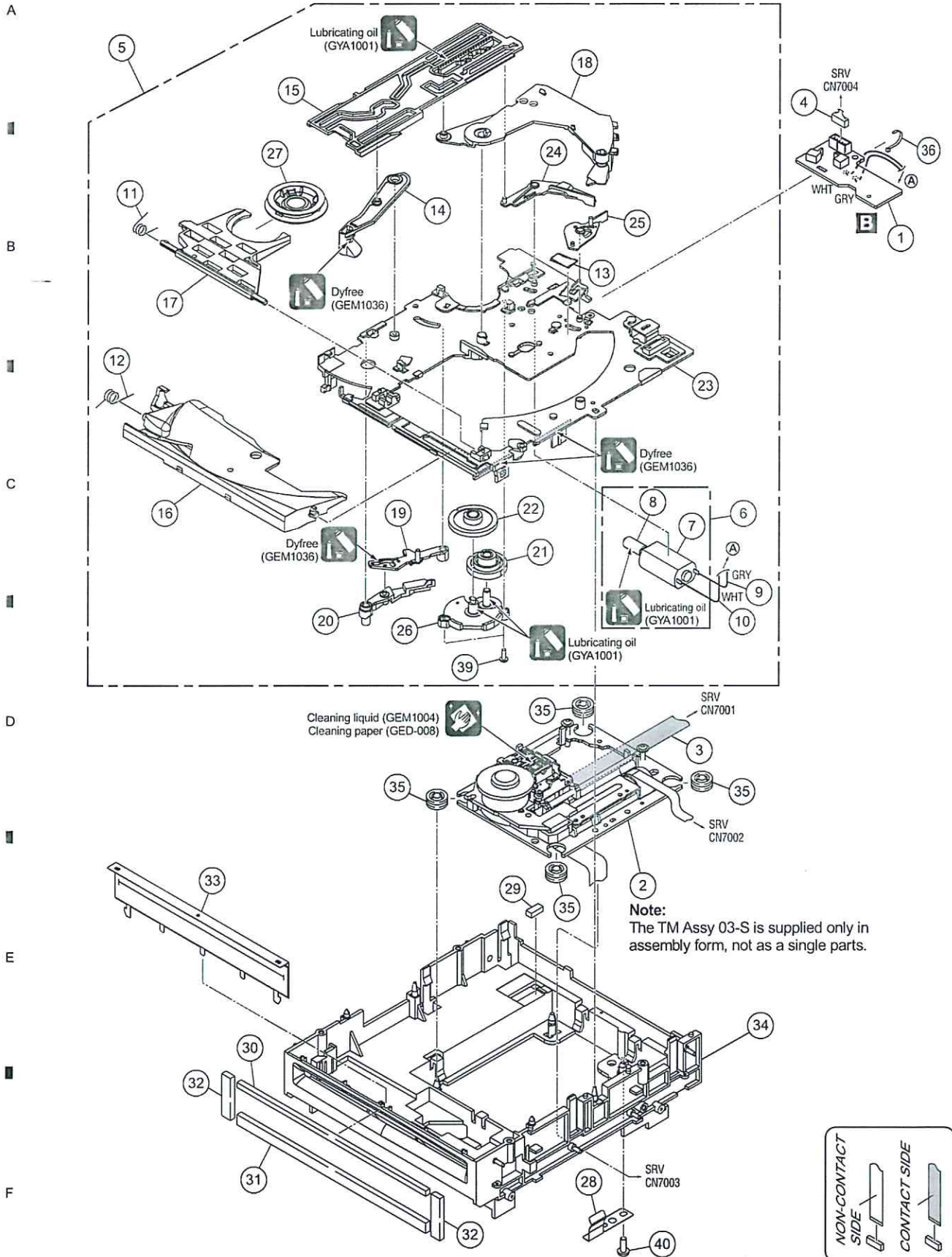

SLOTIN MECHA SECTION PARTS LIST

Mark No.	Description	Part No.	
	1 SLMB Assy	DWS1418	
	2 TM Assy 03-S	VXX3125	
	3 24P FFC	DDD1450	A
	4 Connector Assy	PF05PP-B17	
NSP	5 SLOTIN MECHA Assy	DXA2121	
	6 DC Motor Assy-S	DXX2510	
NSP	7 DC Motor S	DXM1230	
NSP	8 Worm Gear	DNK3910	
	9 Lead Wire	ZWNN1007G28-8-06A	
	10 Lead Wire	ZWNN1007G28-9-06A	
	11 Clamp Spring	DBH1374	
	12 Guide Spring	DBH1375	B
	13 SW. Lever Spacer SV	DEC2831	
	14 Loading Lever	DNK3406	
	15 Main Cam	DNK3407	
	16 Disc Guide	DNK3478	
	17 Clamp Arm	DNK3576	
	18 Eject Lever	DNK3684	
	19 Lever AP	DNK3835	
	20 Lever BP	DNK3836	
	21 Loading Gear	DNK3911	C
	22 Drive Gear	DNK3912	
	23 Loading Base SV	DNK4369	
	24 SW Lever SV1	DNK4370	
	25 SW Lever SV2	DNK4371	
	26 Gear Holder SV	DNK4372	
	27 Clamper 04 Assy	DXB1859	
	28 FPC Guard	DBK1282	
	29 Spacer POR (T3)	DEB1566	
	30 Vessel Cushion A	DEC2852	D
	31 Vessel Cushion B	DEC2853	
	32 Vessel Cushion C	DEC2854	
	33 Front Sheet	DED1132	
	34 Float Base 04 Assy	DXB1838	
	35 Floating Rubber	VEB1351	
	36 Binder (SKB090BK)	ZCA-SKB90BK	
	37		
	38		
	39 Screw	BPZ20P060FTC	E
	40 Screw	BPZ30P080FNI	